

AQUARIA THERMO



1.Data sheet

Descrizione	Description	Unità di misura / Unit	Valori / Value
Capacità di deumidificazione (1)	Dehumidification capacity (1)	l/24h	13,5
Capacità di deumidificazione (2)	Dehumidification capacity (2)	l/24h	22
Volume deumidificabile	Dehumidifiable volume	m ³	140 / 200
Potenza di riscaldamento	Heating capacity	W	1000
Potenza assorbita in deumidificazione (1)	Power absorption in dehumidification mode (1)	W	250
Assorbimento nominale in deumidificazione (1)	Nominal absorption in dehumidification mode (1)	A	1,6
Potenza assorbita massima in deumidificazione (2)	Max. power absorption in dehumidification mode (2)	W	295
Assorbimento massimo in deumidificazione (2)	Max. absorption in dehumidification mode (2)	A	1,7
Potenza assorbita massima in deumidificazione (U.L.U.)	Max. power absorption in dehumidification mode (U.L.U.)	W	315
Assorbimento massimo in deumidificazione (U.L.U.)	Max. absorption in dehumidification mode (U.L.U.)	A	1,8
Potenza assorbita max. in deumidific.+riscaldamento (U.L.U.)	Max. power absorption in dehumidif.+heating mode (U.L.U.)	W	1315
Assorbimento max. in deumidific.+riscaldamento (U.L.U.)	Max. absorption in dehumidif.+heating mode (U.L.U.)	A	6,2
Grado di protezione	Protection level		IP 21
Max pressione di esercizio, lato alta pressione	Maximum operating pressure, high pressure side	Mpa	1,51
Max pressione di esercizio, lato bassa pressione	Maximum operating pressure, low pressure side	Mpa	0,65
Velocità di ventilazione	Fan speeds		1
Capacità tanica	Tank capacity	l	3,5
Portata aria (max)	Air volume (max)	m ³ /h	250
Dimensioni prodotto (Larg. x Alt. x Prof.)	Dimensions (W x H x D)	mm	280x545x385
Dimensioni imballo (Larg. x Alt. x Prof.)	Packing dimensions (W x H x D)	mm	330x575x435
Livello sonoro	Noise level	db(A)	40
Peso (senza imballo)	Weight (without packing)	Kg	17
Peso (con imballo)	Weight (with packing)	Kg	19
Gas refrigerante / carica	Refrigerant gas / charge	Tipo-Type / kg	R134a / 0,175
Cavo di alimentazione (N° poli x sezione mmq)	Power cable (N° pole x section mmq)		3 x 1
Alimentazione	Power supply	V-F-Hz	230 - 1 - 50
Tensione di alimentazione minima/massima	Power supply min - max	V	198-264
Fusibile	Fuse		10AT
Marcature di conformità	Conformity Mark		CE
Enti certificatori	Certification Mark		-
CONDIZIONI LIMITE DI FUNZIONAMENTO		OPERATIONAL LIMITS	
Temperature di esercizio massime	Maximum operating temperature	(U.L.U.) DB 35°C - WB 31°C	
Temperature di esercizio minime	Minimum operating temperature	(L.L.U.) DB 2°C - WB 1°C	
CONDIZIONI DI PROVA		TEST PARAMETERS	
		(1) DB 27°C - WB 21°C (27°C - 60% RH)	
		(2) DB 32°C - WB 29°C (32°C - 80% RH)	

2. Control panel keys and display

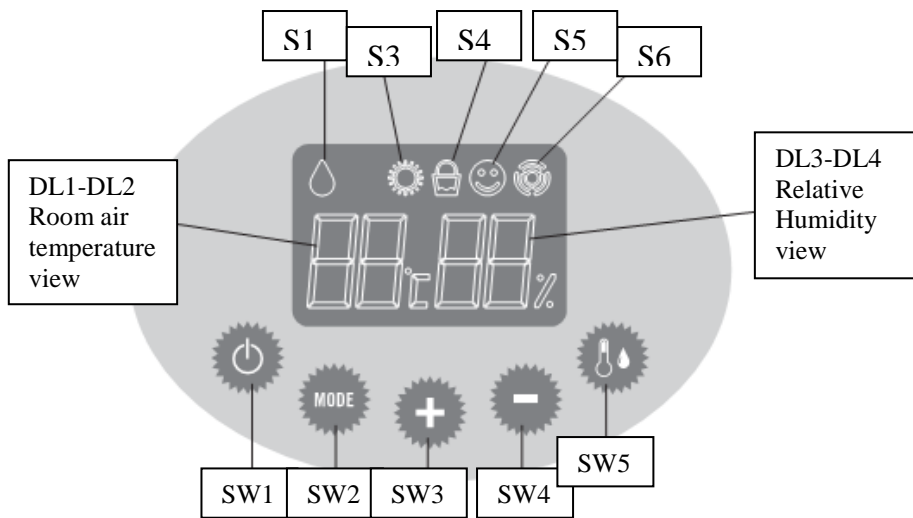

S1:Dehumidification

S3:Heating mode

S4:Full water tank/No water tank.If blinking with frequency of 1.25Hz,continuous discharge function is enabled

S5:Auto mode

S6:Purifying mode

SW1:Turn on/Stand-by key

SW2:Mode selection key.

SW3:Humidity increasing key (value between 30% and 90%)

SW4:Humidity decreasing key (value between 30% and 90%)

SW5:Room humidity/temp. key

DL1,DL2,DL3,DL4: In normal working operations,they display the Set Temperature and Set Relative Humidity values respectively (according to the function selected) both in blinking mode and with duration of 5 seconds.Furthermore following information can be shown:

<i>Digit DL1 and DL2</i>	<i>Digit DL3 and DL4</i>	<i>Corresponding information</i>
OFF	30% - 90%	Relative humidity set value
6°C - 30°C blinking	30% - 90% blinking	Room air Temperature and relative humidity measured
OFF	Hr blinking	Humidity sensor / room air NTC sensor malfunction
OFF	tE blinking	Evaporator NTC sensor malfunction
OFF	LO blinking	Low temperature alarm
-9°C - 50°C	At	Autotest mode, evaporator temperature value
Co	20 - 50	Setup mode: compressor defrosting ON time
Cf	3 - 15	Setup mode: compressor minimum OFF time
Ft	-9 - 9	Setup mode: frost accumulation temperature
St	0 - 9	Setup mode: end of defrosting temperature
tC	20 - 40	Setup mode: set point temperature in combined mode

3. Buzzer and backlight

<i>Activation mode</i>	<i>Corresponding information</i>
Single short pulse	Keys pressed on control board confirmation
Two short pulses	System activation (through SW1)
Three short pulses	Parameter EEprom writing confirmation
Five short pulses	Autotest and Set-up modes activation
Intermittent for 15 seconds	Tank micro switch opening Probe malfunctions Evaporator exchanger low temperature malfunction

- As soon as the tank switch opens the unit has to switch-off all the active loads (except the fan whose switching off has to be delayed by 45 seconds), switch-on of the corresponding symbol in fixed mode and enable an intermittent acoustic signal for 15 seconds; press any key with the acoustic alarm active or re-close the microswitch to silence the alarm.
- The board confirms any command by a brief acoustic signal and switching on the LCD backlight for 10 seconds.

4. Working modes description

4.1 STAND-BY MODE

This mode can be selected by pressing SW1 key on the control board, and is signalled as shown on par. 2. In this condition, if the key is pressed again, all the functions previously selected are restored (operating mode, set-point, etc.).

When switching to stand-by mode all board outputs are switched OFF, but if compressor and/or resistor were active, the fan only continues to run for 45 seconds further (with same speed) before stopping.

In STAND-BY mode (and only in this mode) it is possible to enter the parameter programming mode where new parameter values can be stored in eeprom (see related paragraph).

4.2 AIR CLEANING MODE

When selected by SW2 (see par.2) the fan is switched on, while is switched off only in the following cases: the tank switch opens or any alarm occurs.

When this function is selected, the symbol S6 is switched ON, while digits DL-DL2 and DL3-DL4 show the actual room temperature and Relative Humidity values acquired (button SW5 is disabled).

The fan speed is always the low speed (output FAN1 on power board shall be energized).

4.3 DEHUMIDIFICATION MODE

Selected by SW2 and signalled as shown on par. 2.

Compressor and fan (low speed, power board output FAN1) are switched on if the minimum OFF time (**Cf**) has elapsed and if the relative humidity value is higher than the set point + 3%; compressor and fan remain ON as long as the relative humidity value is above the set point - 3%; when below the set point - 3%, compressor and fan switch off (the fan is switched-off 45 seconds later than the compressor) and remain off for a minimum time equal to **Cf** (measured from the compressor shut down), at the end of which the

compressor and the fan are switched back on again if the relative humidity value is greater than the set point +3%.

The relative humidity (RH) set point can be adjusted from 30% to 90% in steps of 5%. By pressing the UP (SW3) or DOWN (SW4) keys the set point value is increased or decreased by 5%.

4.4 AUTOMATIC MODE

Selected by SW2 and signalled as indicated on par.2. On digits DL-DL2 and DL3-DL4 are indicated measured Room air temperature and relative humidity values (the SW5 key is disabled).

The behaviour is like Dehumidification mode, but with the difference that humidity set point is no more displayed and adjustable (SW3 and SW4 are disabled) but rather is automatically established from appliance with reference to Room air measured temperature, according to this table:

Room air temperature	Relative humidity set point
<16°C	60%
≥16°C, ≤20°C	50%
>20°C	40%

It must be respected the delay of **Cf** minutes between 2 consecutive activations of compressor and the delay of 45 seconds of fan switch OFF starting from compressor shut down.

The fan is switched to high speed (output FAN2 on power board shall be energized) if the difference between measured relative humidity value and humidity set point is higher than 15%, and is switched to low speed (output FAN1 on power board shall be energized) in all others cases.

4.5 COMBINED DEHUMI+HEATING MODE

Compressor, resistor and fan are switched on if the Dehumi+Heating function is selected (by SW2, see par. 6), if the minimum OFF time of the compressor (**Cf**) has elapsed and if the relative humidity value is greater than the set point +3; compressor, resistor and fan remain on as long as the relative humidity value is greater than the set point -3; when it is below the set point -3, compressor, resistor and fan switch off (fan switch-off is delayed by 45 seconds with respect to the compressor and the resistor) and remain off for a minimum time equal to **Cf** (measured as from switch-off of the compressor), at the end of which compressor, resistor and fan switch back on again if the relative humidity value is greater than the set point +3.

The set point can be adjusted from 30% to 90% RH in 5% steps; pressing the UP (SW3) or DOWN (SW4) keys increases or decreases the set point value by 5%.

The resistor switches off if the ambient temperature is above **tC** and is re-activated if the Room air temperature is below **tC-2°C**. In this mode the display on the digits (and the function of the SW5 key) must be the same as in 'Dehumidification' mode. The fan speed is always the high speed (output FAN2 on power board shall be energized).

5. Other functions and modes

5.1 Auto-recovery function

The ON/OFF status, the set point, the operating mode (including tank switch inhibition) are saved in EEPROM memory. After a black-out or a power mains failure the unit recovers all operations previously set without observing any compressor **Cf** OFF time.

5.2 Compressor switching

Compressor can be switched ON only when **Cf** minutes have elapsed starting from previous compressor shut down.

5.3 Defrosting function

When a frost condition occurs (evaporator temperature < **Ft** and compressor ON) the compressor remains on for a maximum time equal to **Co** minutes, then defrosting takes place (fan on at minimum speed, resistor not active, compressor off) which terminates when the pre-set temperature **St** is reached (evaporator temperature > **St**), compatibly with the minimum compressor OFF duration **Cf** (defrosting interval cannot be shorter than **Cf** minutes).

If frost condition is detected and RH set point is reached within **Co** minutes, the compressor has to be stopped but the fan remains on until the defrosting end temperature is reached.

5.4 Inhibition of Tank Full switch

The tank full switch is ignored: this function is accessed only if the level switch is open (tank full or absent) by keeping the SW3+SW4 keys pressed for 3 seconds; the S4 symbol blinking indicates that the function is active. The function is automatically terminated when the level switch is closed.

5.5 Autotest mode

When the unit is in Stby mode, by pressing the keys SW4+SW5 for 3 seconds (SW4 first), the following sequence is started:

- all LCD symbols are switched ON for 3 seconds;
- the SW release is shown for 3 seconds;
- the fan is switched ON at max speed, both compressor and the resistor are powered, the LCD shows the code **At** on digits DL3 and DL4 and evaporator probe temperature on digits DL1 and DL2.
- The compressor remains ON continuously, regardless of the RH set point and tank microswitch condition; the defrosting function is disabled and compressor can be powered even if **Cf** minutes have not elapsed from previous compressor shut down.

The tank level symbol (S4) is switched ON if the tank is absent/full (microswitch open), and remains OFF if the tank is present (board input closed).

By pressing the key SW5 the unit shows the measured room air temperature and relative humidity values (like during normal operations)

Press the stand-by key (SW1) or disconnect the power supply to quit the auto test mode.

5.6 Setup mode

By pressing the keys SW5+SW3 for 3 seconds in stand-by mode you access the setup: by pressing key SW5 you go to the next parameter, SW5+SW3 or SW5+SW4 increase or decrease the value, when the SW5 key is released the current value is stored in the memory.

In order to quit the setup mode, press the SW1 key or disconnect the power supply.

The default values shown in the table below are programmed during the electronics test process.

<i>Mnemonic</i>	<i>Range scheduled</i>	<i>Parameters set</i>	<i>Description</i>
Co	20 - 50 min	20	Compressor in defrosting ON time
Cf	3 - 15 min	3	Compressor minimum OFF time
Ft	-9 – 9 °C	1	Frost accumulation temperature
St	0 – 9 °C	3	End of defrosting temperature
tC	20 – 40°C	26	Temperature set point in combined mode

6.ALARMS

6.1 PROBES ALARM

Any failures in the probes are displayed by **Hr** or **tE** blinking for the humidity sensor probe/ambient probe and evaporator probe respectively; in the case of a failure in the probes all the loads are de-activated (except the fan whose switching off has to be delayed by 45 seconds) and an intermittent acoustic signal is emitted (which can be silenced by pressing any key) with duration of 15 seconds.

The humidity probe signals the failure even if it measures a room relative humidity percentage below 22%, a condition in which the unit must be deactivated. Operation is automatically restored as soon as the relative humidity rises back above 22%.

6.2 LOW TEMPERATURE ALARM

If after 30 minutes of operation in defrosting mode (compressor stopped and fan working) the evaporator temperature does not exceed **St**, then the fan is stopped, the display shows the alarm code **LO** blinking and an emission of an intermittent acoustic signal is enabled (which can be silenced by pressing any key) with duration of 15 seconds.

Reset of this alarm status occurs automatically as soon as the evaporator temperature rises above the value stored in parameter **St**.

7. WIRING DIAGRAM

- A1 - Electronic card (power)
- A2 - Humidity/temperature sensor card
- A3 - Electronic card (control)
- B1 - Humidity/temperature sensor
- B2 - Evaporator sensor
- E1 - Heating element (for the THERMO version only)
- F1 - Compressor thermal cutout
- RY102 - Compressor relay
- RY104 - Fan relay
- RY101 - Heating resistance relay (for the THERMO version only)
- M1 - Motor-driven compressor
- M2 - Fan
- S1 - Tank full/missing microswitch
- S301 - Signal key for the humidity/room temperature detected
- S302 - Desired humidity decrease key
- S303 - Desired humidity increase key
- S304 - Switch-on/stand-by key
- S305 - Operating mode selection key
- T1 - Transformer

